







KOFFERTRÄGER EXTREME



Case carrier | Portamaletas | Porte-bagages | Supporto per valigie

Art.-Nr: **13600-00X**

LEGENDE/KEY/FILE LÉGENDE

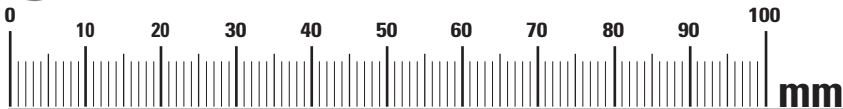
-  **Anbau Tipp**
Fitting tip
Astuce de montage
-  **Achtung**
Attention
Attention
-  **Vergößerung**
Magnification
Grossissement
-  **Montagepaste**
Fitting lubricant
Lubrifiant de montage
-  **Schraube**
Screw
Vis
-  **Schraubensicherung**
Thread locking fluid
Freinfiets
-  **Drehmoment**
Torque
Torque
-  **Reiniger**
Cleaner
Nettoyant



#	Bauteil component composant	DE Die Farben der Abbildungen dienen nur der Veranschaulichung. EN The colors are for illustrating purposes only. FR Les couleurs utilisées sont à titre indicatif seulement.	DIN	ISO	Menge quantity quantité
1	Zylinderschraube / Cylinder head screw (black) M8x60 (Torx)		912Z	4762	2
2	Zylinderschraube (schwarz) / Cylinder head screw (black) M8x80 (Torx)		912Z	4762	2
3	Linsenflanschschraube / Lens head screw M8x20 (Torx)		7381A2	7381	4
4	U-Scheibe / Washer M8		125A2	7089	8
5	Sechskantmutter / Hex nut M8		985A2	10511	4
6	Rechter & linker Kofferträger / Right & left luggage rack				2
7	Rechter & linker Halter / Right & left bracket				2
8	Querstrebe / Cross brace				1
9	Schraubensicherung / Thread locking fluid				1
	Ausstattung: OHNE Vario Kofferhalterung Features: WITHOUT Vario case bracket. / Caractéristiques: SANS support de boîtier Vario				
10	Vorderen Alu-Distanzhülsen / Alu sleeves in front øD 16,0 - ød 9,2 - h 30,0 mm				2
11	Hinteren Alu-Distanzhülsen / Rear Alu sleeves øD 16,0 - ød 9,2 - h 46 mm				2
	Ausstattung: MIT Vario Kofferhalterung Features: WITH Vario case bracket. / Caractéristiques: AVEC support de boîtier Vario				
12	Vorderen Alu-Distanzhülsen / Alu sleeves in front øD 16,0 - ød 9,2 - h 19,5 mm				2
13	Hinteren Alu-Distanzhülsen / Rear Alu sleeves øD 16,0 - ød 9,2 - h 13,0 mm				2

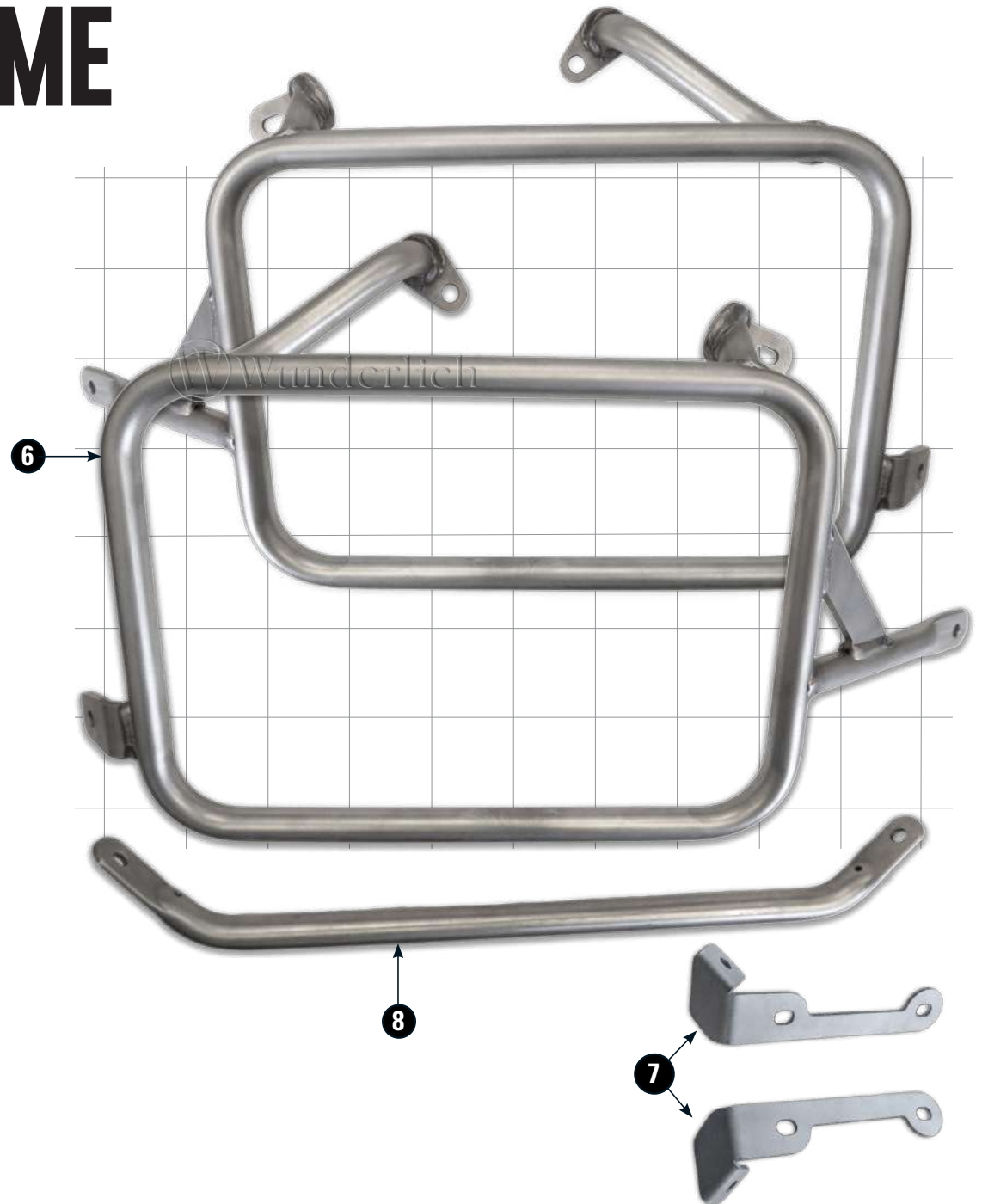



Halter lose vormontieren und erst nach dem Ausrichten mit angegebenen Drehmoment festziehen.
Pre-assemble the bracket and support loosely and only tighten to the specified torque after alignment.
Pré-assembler le support et l'étrier sans les serrer et ne les serrer au couple spécifié qu'après l'alignement.

AUSSTATTUNG: OHNE Vario Kofferhalterung
Features: **WITHOUT** Vario case bracket / Caractéristiques: **SANS** support de boîtier Vario

3.1

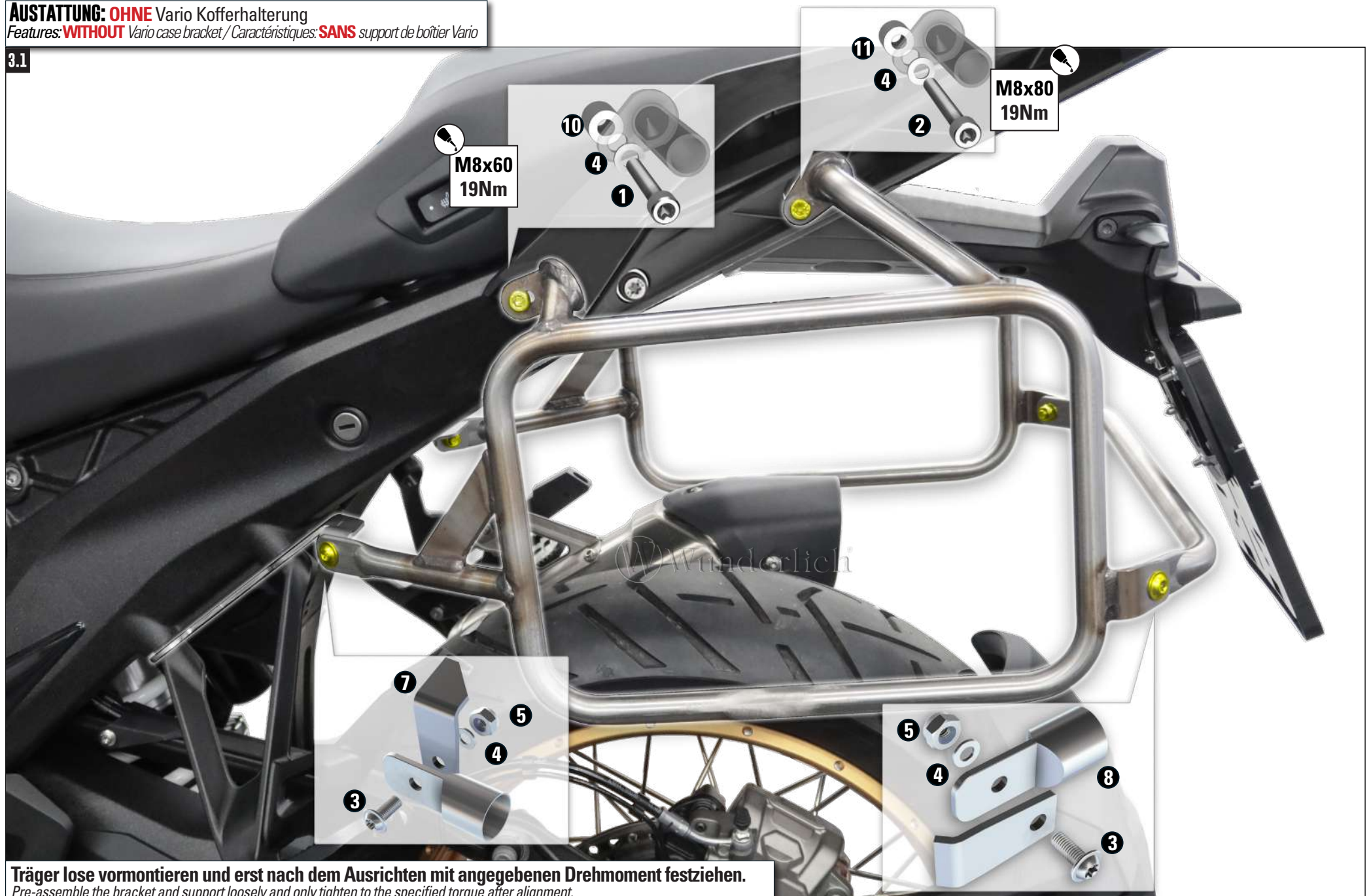

Träger lose vormontieren und erst nach dem Ausrichten mit angegebenen Drehmoment festziehen.

*Pre-assemble the bracket and support loosely and only tighten to the specified torque after alignment.
Pré-assembler le support et l'étrier sans les serrer et ne les serrer au couple spécifié qu'après l'alignement.*

AUSSTATTUNG: MIT Vario Kofferhalterung
Features: WITH Vario case bracket / *Caractéristiques: AVEC* support de boîtier Vario

3.2

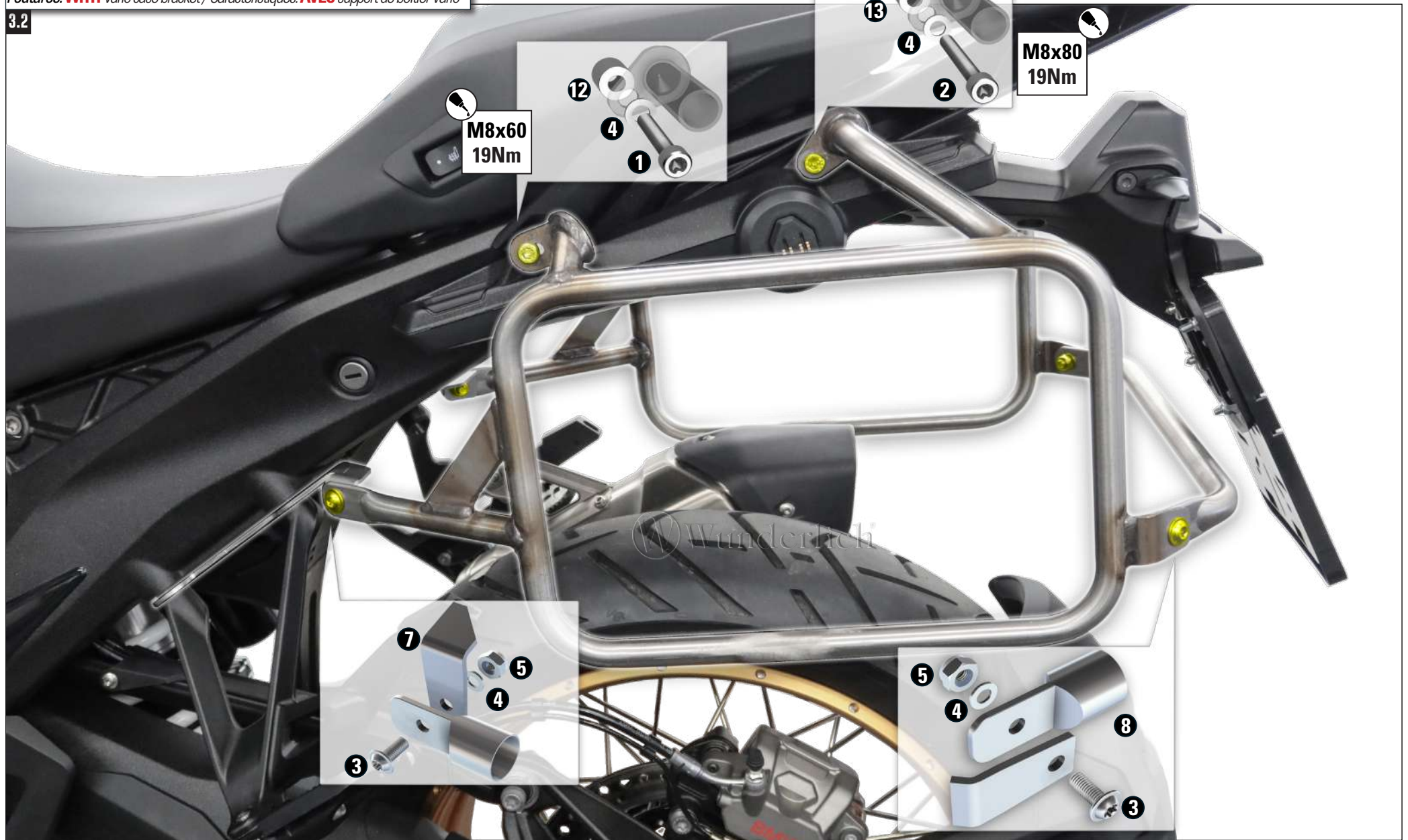

Träger lose vormontieren und erst nach dem Ausrichten mit angegebenen Drehmoment festziehen.

Pre-assemble the bracket and support loosely and only tighten to the specified torque after alignment.
Pré-assembler le support et l'étrier sans les serrer et ne les serrer au couple spécifié qu'après l'alignement.

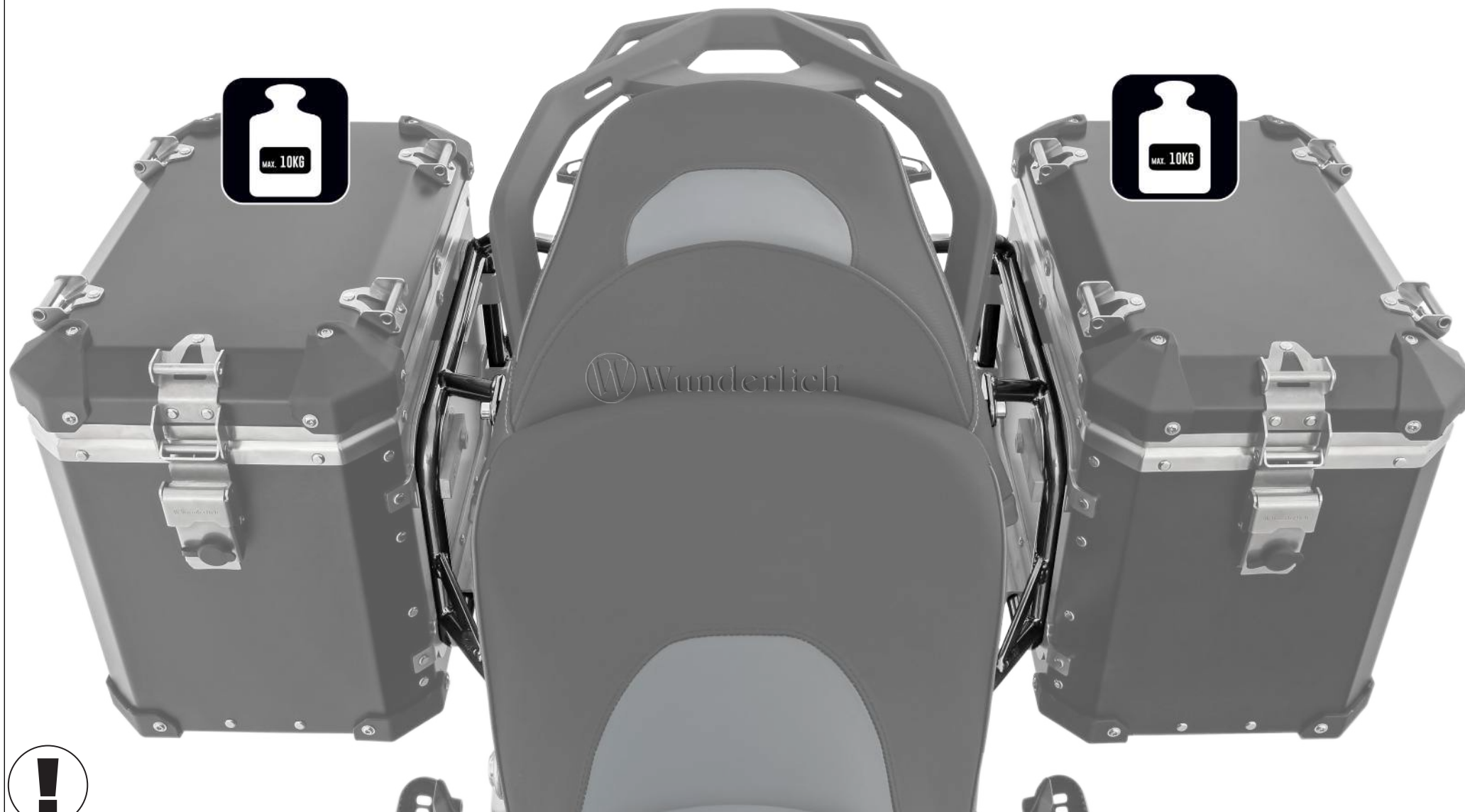

Verriegelung des Koffers und die Verschraubung des Trägers, vor Fahrtantritt prüfen. Verschlüsse der Deckel müssen verriegelt sein. Empfohlenes Tempolimit mit Zuladung 130 km/h. Ungleichmäßiges oder unsachgemäßes Beladen kann das Fahrverhalten negativ beeinflussen.

Check before each journey that case/top case is securely attached to the carrier on the vehicle. Locks must be closed.

Recommended speed limit with load: 130 km/h (80 mph). Uneven or improper loading can affect the driving behaviour in a negative way.

Avant chaque voyage, vérifiez que la valise/le top case est bien fixé(e) au porte-bagages du véhicule. Les serrures doivent être fermées.

Limite de vitesse recommandée avec charge : 130 km/h (80 mph). Un chargement irrégulier ou incorrect peut avoir des conséquences négatives sur le comportement de conduite.